

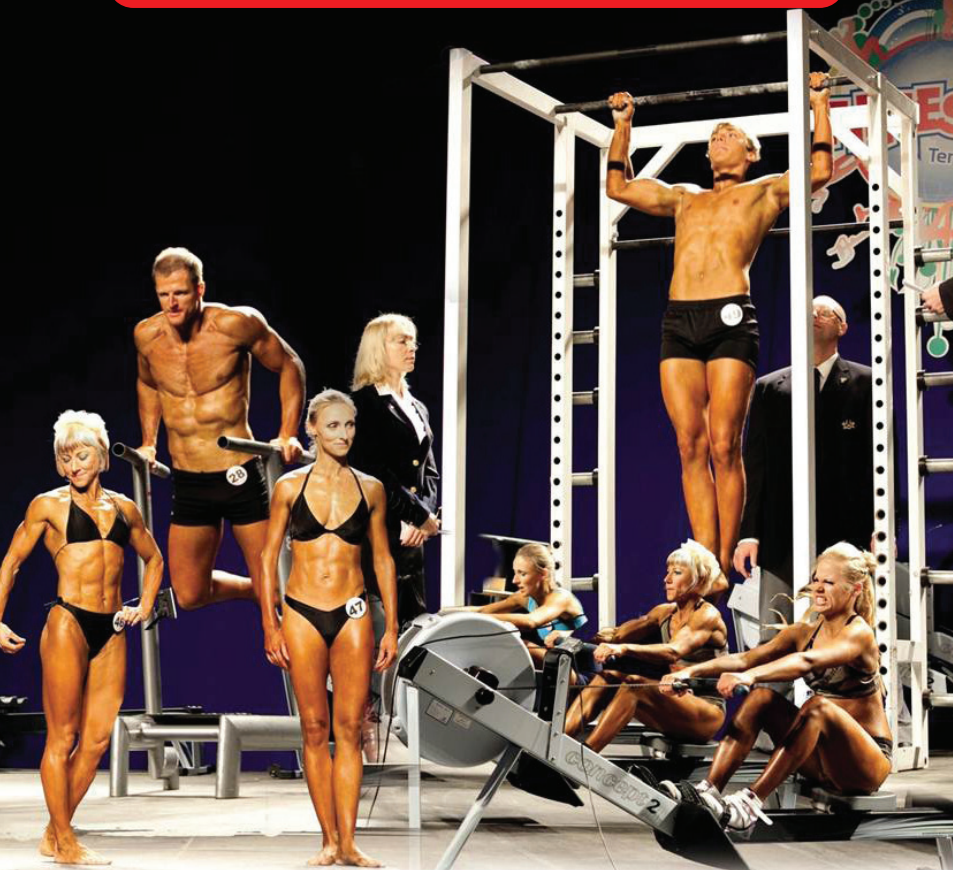

# ATHLETIC FITNESS



New sports discipline that combines various elements of strength, endurance as well as balanced physique.

***Real sport for fit men and women!***





**ATHLETIC  
FITNESS**

## ***Key factors***

**H** *healthy lifestyle*

**O** *opportunity for wide age levels*

**P** *personal satisfaction*

**E** *energy from a balanced body*

# Rules



**ATHLETIC  
FITNESS**

## **Rounds**

### **Elimination**

If there are more than 15 competitors in one category, the elimination is done by assessing the physique in four quarter turns as in fitness. The procedure and the judging criteria are the same as in fitness. Men`s attire as in fitness, women`s attire as in bodyfitness (black two-piece bikini). Any kind of footwear is prohibited.

### **Prejudging**

**ROUND 1** (Physique Round; Quarter Turns). Presentation, scoring and assessment of R1 as in fitness. In R1 every athlete gets an individual placing. Ties are broken using the relative placement method.



**ROUND 2** (Strength Round; Pullups and Dips). Pullups are performed first. There must be at least 3 stations (one for every 5 athletes). The athletes are grouped in numerical order (station 1: numbers 1-5, station 2: numbers 6-10, station 3: numbers 11-15). Three judges count the repetitions at each station: one judge must see from the level of the bar that the chin reaches over the bar, one judge must stand behind the athlete to see that the arms are completely straight (locked out) at the bottom position and one judge must see from the side that there is no swinging of the body. Every judge counts the correct repetitions with a clicker. Judges may give instructions to the athlete during the performance but no argumentation is allowed on the stage after the performance. The highest and the lowest number of repetitions is eliminated, score will be the average amount of reps. When all the athletes have completed their pullups, dips will follow. The dips are performed in the same groups and order to give equal time for recuperation. One judge stands behind the athlete and other judges at both sides to see that the elbows are locked out at the top position, the depth is adequate (shoulders must go below the elbow line) and there is no swinging of the body. The tempo used to perform pullups and dips must be moderate, so that the judges can distinguish and count correct repetitions.



ATHLETIC FITNESS



ATHLETIC FITNESS



**SCORING OF ROUND 2.** According to the number of reps, each athlete will get a place in pullups and a place in dips. If two or more athletes have the same number of repetitions, they will get the same place. the Place in Round 2 = the place in pullups + the place in dips. Ties will not have to be broken in this round.

**ROUND 3** (Endurance Round; Ergometer rowing). There must be at least 5 ergometers. Athletes are divided into heats according to their placings after R1 and R2. (In case of an equal score, the place in R1 is decisive.) The lowest placed athletes perform in the first heat and the highest placed athletes in the last heat. Behind each ergometer a judge must stand to prevent the movement of the ergometer during rowing. The distance for ergometer rowing is 1000 meters. After the last heat all the athletes get their placings in Round 3. It is possible but very rare in practice that two or more athletes finish with the same time. In that case they will get the same place in R3.

**NOTE:** an alternative for Ergometer rowing machines can be Speed jumping or Plyometric Exercise jumping. The 3rd Round method will be mentioned in the Inspection Report.



**SCORING OF PREJUDGING.** the Prejudging place = R1 place + R2 place + R3 place. All three Rounds will be 1/3 of the total score. In case of a tie, the placing in R1 is decisive.

## ***Finals***

The top six athletes advance to the finals. They start from zero and carry out the full program: Physique Round, Strength Round and Endurance Round.

**FINALS ROUND 4** (Physique Round; Quarter Turns). R1 is presented, scored and assessed as in fitness Finals. Attire is the same as in Prejudging.

**FINALS ROUND 5** (Strength Round). One by one (in numerical order) the six finalists perform pullups and then dips.

**FINALS ROUND 6** (Endurance Round). Six ergometers are needed, so that all the finalists can perform in one heat. Alternatively Plyometric Speed jumps will be performed.

**SCORING OF FINALS.** Scoring system is the same as in Prejudging.

## ***Categories***

Women -163cm and +163cm

Men -175cm and +175cm



# Descriptions of technique



## *Chin-ups:*

It is required to use an overhand grip. The maximum width of the grip is 1 meter : from the little finger to the little finger. The body is in a hanging position, meaning that the elbows are locked out and the back straightened out. The body is now pulled upwards until the chin reaches over the bar, then lowered back to the starting position. During the exercise, the body may only move in a vertical way, the positioning of the feet must not be changed. The tempo used to perform pull-ups must be moderate, so that the judges could distinguish and count the correct repetitions.



## *Dips:*

Before beginning the exercise, the body must be in a locked position, meaning that the elbows must be locked out, and the body is in a vertical position. The body is then lowered until the shoulders have reached below the elbow line. During this exercise, the body must not swing and must move only in a vertical way, and, once again, the positioning of the feet must not be changed. The tempo used to perform dips must be moderate, so that the judges could distinguish and count the correct repetitions.



## *Ergometer rowing:*

This exercise consists of two phases; the preparatory phase and the drive phase. At the end of the preparatory phase, the arms are extended forward until straight, the shoulders and the neck are in a neutral position, and the upper body slightly bent forward. The shins are vertical and the legs firmly bent from the knees. The space between the seat on the monorail and the knees should be about 15-20cm. The drive phase begins with a push as pressure is exerted to the foot plate until the legs have straightened out. The upper body is then slightly leaned back by contracting the core muscles and the hands are drawn back to the lower ribs, the arms must remain straight from the wrists.

The drive phase ends, and the preparatory phase begins by promptly bending the upper body forward, then allowing the knees to bend and slide the seat forward on the monorail.

The knees may be bent only after the arms have reached over the knees. When compared to the clock, it is recommended that the body moves from eleven o'clock to one o'clock, excessive bending is not recommended. In order to achieve rhythm and smoothness, it is necessary to ensure that the drive phase generates enough force, and the preparatory phase lasts long enough to allow the muscles to relax in order to prepare for the next drive phase. It is recommended to start with three partial and forceful strokes in order to achieve necessary velocity for completing the distance.



# Equipment



# ATHLETIC FITNESS

## Round 2

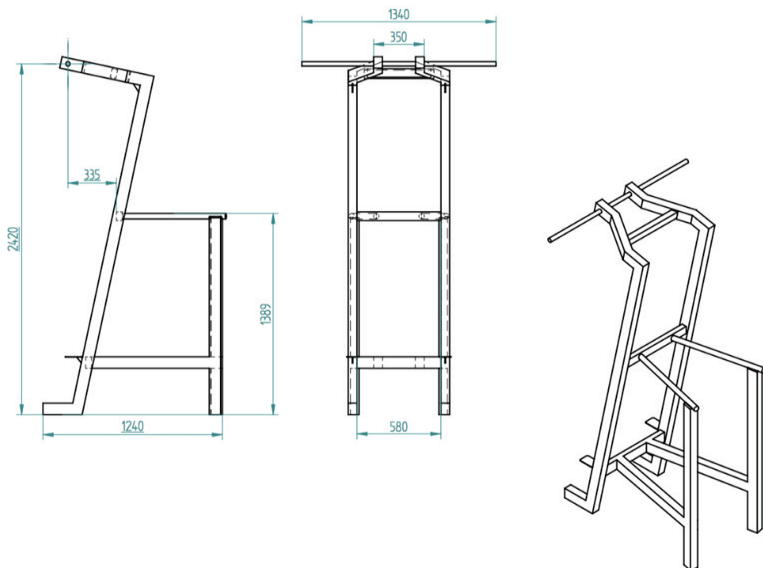

## Round 3





 **ATHLETIC  
FITNESS**

 **ATHLETIC  
FITNESS**

 **ATHLETIC  
FITNESS**



# **ATHLETIC FITNESS**

## **SPORT FOR ALL**

### **Challenges for wider target group**

- *Athletic Fitness without physique round*
- *3 rounds: 1. chin-ups, 2. dips and 3. Rowing or Plyometric Speed jumps*
- *A broad group of participants*
- *Competitions are held in gyms*
- *World-wide scores online, the competition will never stop*

# ENDURANCE AEROBIC

## alternative exercises

In case Rowing equipment is not available, as may happen in open courts, beach events or local gym facilities. Plyometric jumps will replace the Rowing in the following way:

### 1. **Straddle plyometric jumps**

(recommended for beginners level).

**Material:** aerobic step, approximate size: height 26 cm, width 36 cm and Volley ball, 200/300 grams.

**Time:** 2 minutes

**Description:** Start with one foot on either side of the box (Straddle). Hold the ball with two hands and keep the arms down. Bend the knees (as in a squat) and jump on top of the box with two feet together, raising the ball above the head. Jump back down with two feet, one foot either side of the box, lowering the ball to the bottom position. Do as many jumps on the box as possible in 2 minutes.





## 2. Lateral plyometric jumps

(for advanced athletes level)

### **Material:**

aerobic step, approximate size:  
height 26 cm, width 36 cm

**Time:** 2 minutes

### **Description:**

Start with both feet on one side of the box. Jump with two feet together to the other side of the box (lateral). Do as many jumps as possible in 2 minutes.

*See videos on [ifbb.com](http://ifbb.com)*

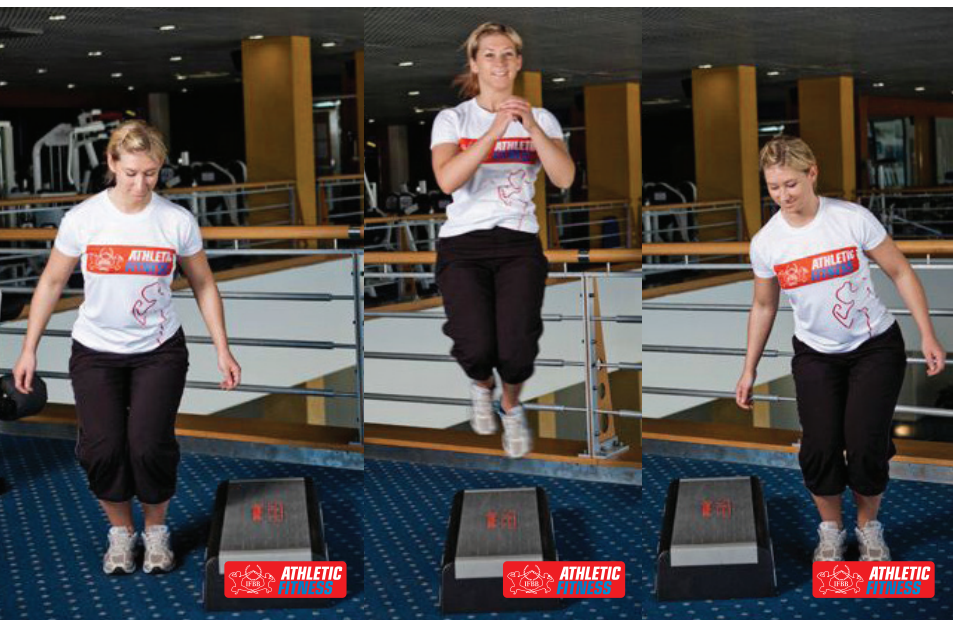

# IFBB



# ATHLETIC FITNESS

The driving force behind the Athletic Fitness is the **IFBB**, a world sport organization, which has 186 countries as members. It was founded in 1946 and organizes over 1400 events per year.

The **IFBB** is a member of Sport Accord, International Council of Sport Science and Physical Education (ICCSSPE) and other prestigious organizations, being as well, recognized by WADA and in compliance with the antidoping control.

**The Fitness lifestyle** is followed by millions of people world-wide. Regardless of age, sex, and previous physical condition, bodybuilding training and nutrition can help individuals to achieve balanced bodies with a proper control of body fat and in good health.



# Contacts

IFBB HQ

**Dr Rafael Santonja**

President of IFBB

Phone: 0034-91 535 2819

Fax: 0034-91 536 1518

Address: Dublin 39-I St.

Las Rozas (Európolis)

Postal code 28232

Madrid Spain

E-mail: [internacional@santonja.com](mailto:internacional@santonja.com)

## **Arnold Tokko**

Athletic Fitness Supervisor

Phone: +372 505 7809

Fax: +372 677 4888

Address: Telliskivi 51

Tallinn, Estonia

10611

E-mail: [arnold@ifbb.ee](mailto:arnold@ifbb.ee)

Skype contact: [arnold\\_tokko](#)



*Official drink of Athletic Fitness:*

**ATHLETIC FITNESS**

**HOPE Drink**